

# nimco

hydraulic systems

[www.nimco-controls.com](http://www.nimco-controls.com)

## ELECTRICAL CONTROL UNITS





Page 4	System Options Overview
Page 5	Technical Data
Page 6	EPC 100 1-Axis Controller
Page 7	EPC 300 2-Axis Controller
Page 8	EPC 700 4-Axis Controller
Page 9	EPC 350 3-Axis Controller
Page 10	EDB 64 Driver Unit
Page 12	CC8 Control Card
Page 13	Driver Box



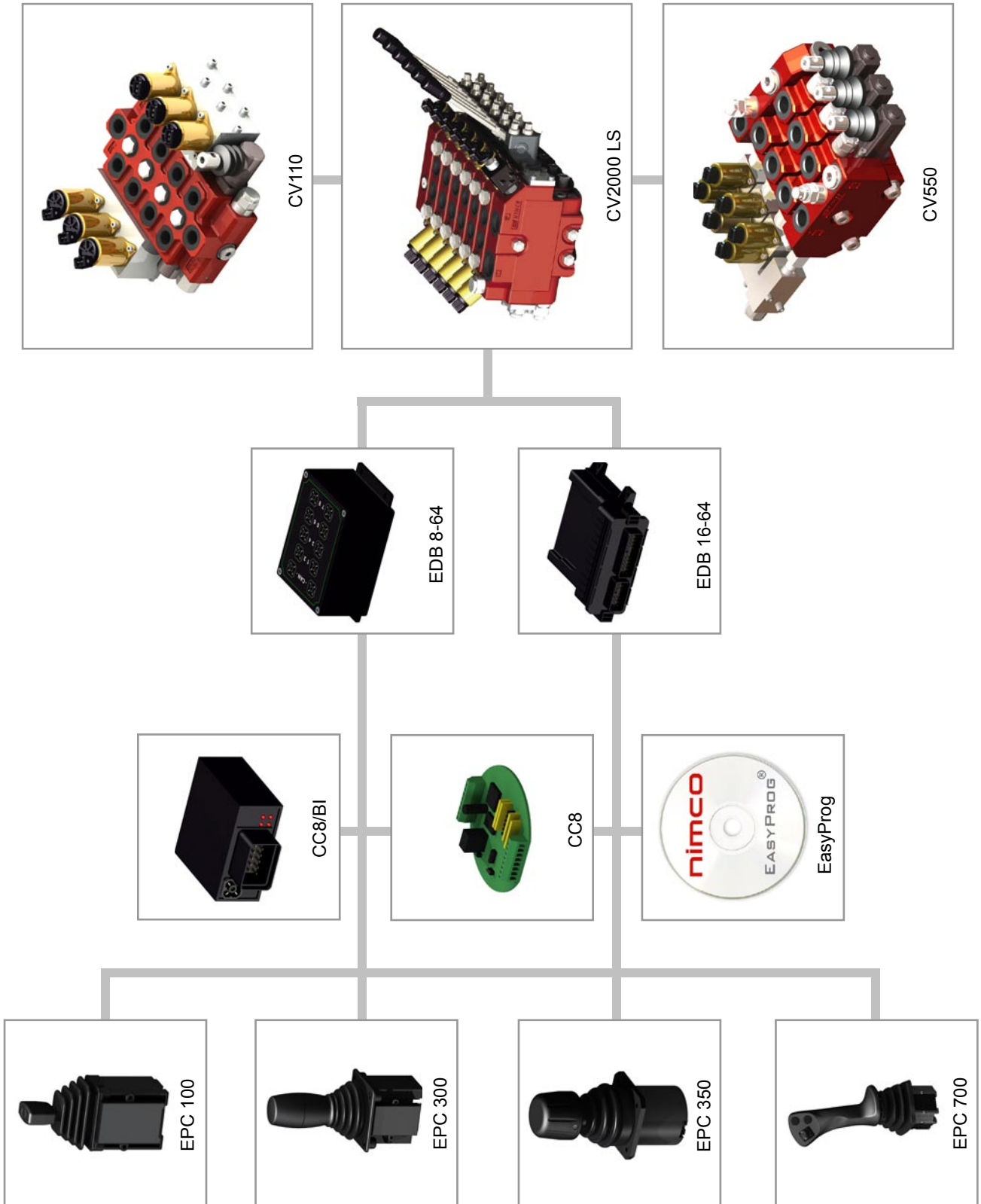

The EPC 100 is a single axis analogue control joystick. Angular operating range is  $\pm 20^\circ$  and the operating principle is non-contacting rotating magnetic field over hall-sensor. It is short circuit-proof (short circuit duration: unlimited).

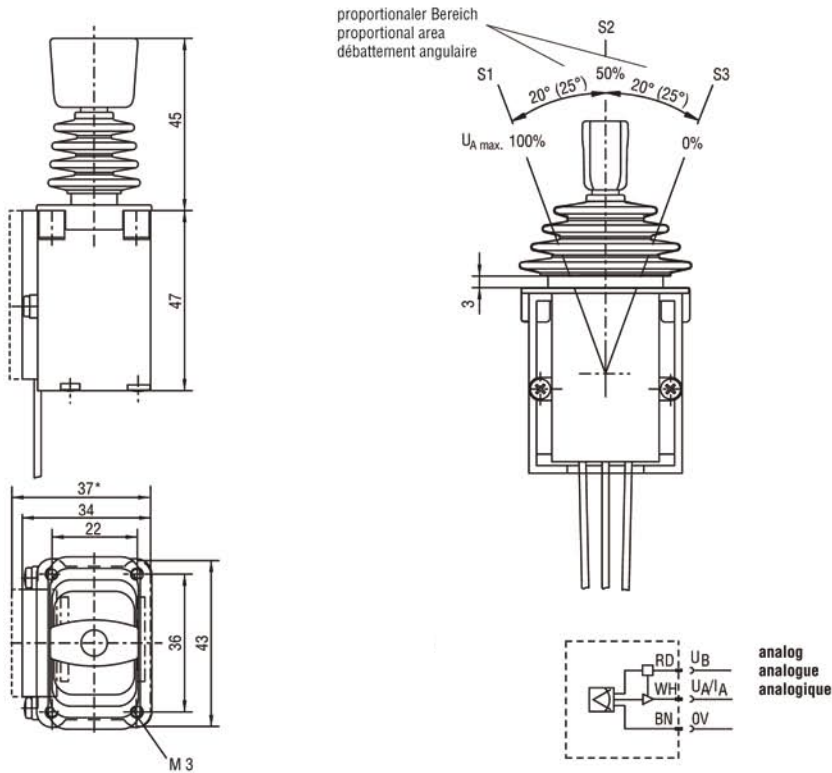

Type No.	Operating Voltage	Output Signal	Current Consumption	Load Resistance	Centre Position
EPC 100 A1	10–30 V DC	4–20 mA	12 V -> 18 mA	1)	12 mA
EPC 100 A6	4,5–5,5 V DC	0,5–4,5 V DC ratio./propor	max. 10 mA	> 20 k $\Omega$	typ. 2,5 V
EPC 100 A7	10–30 V DC	0,5–4,5 V DC	12 V -> 15 mA	> 20 k $\Omega$	typ. 2,5 V

1) with Operating Voltage : 10 V < 250  $\Omega$   
30 V < 1250  $\Omega$

The EPC 300 is a two axis analogue control joystick. Angular operating range is  $\pm 20^\circ$  in both directions and the operating principle is non-contacting rotating magnetic field over hall-sensor. It is short circuit-proof (short circuit duration: unlimited). It can be fitted with 1-3 on/off push buttons on the top of the grip as an option.

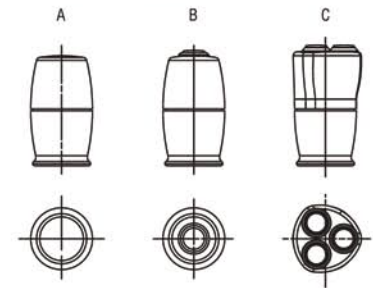
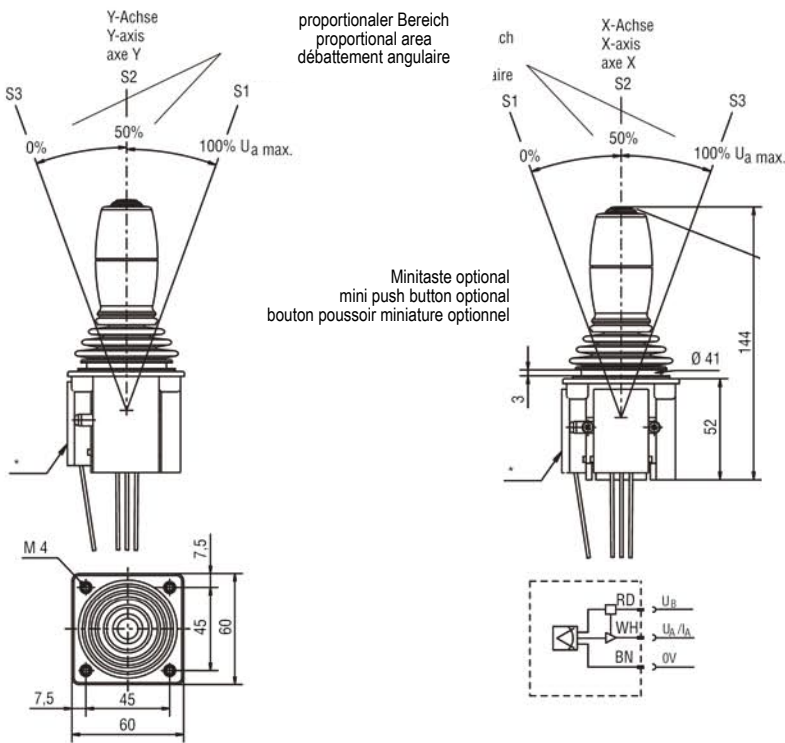

Griffversion (wahlweise)  
knob (alternatively)  
levier (facultativement)

Type No.	Operating Voltage	Output Signal	Current Consumption	Load Resistance	Centre Position
EPC 300 A1	10–30 V DC	4–20 mA	12 V -> 18 mA	1)	12 mA
EPC 300 A6	4,5–5,5 V DC	0,5–4,5 V DC ratiom./propor	max. 10 mA	> 20 kΩ	typ. 2,5 V
EPC 300 A7	10–30 V DC	0,5–4,5 V DC	12 V -> 15 mA	> 20 kΩ	typ. 2,5 V

1) with operating voltage : 10 V < 250 Ω  
30 V < 1250 Ω

The EPC 700 is a two axis heavy duty analogue control joystick. Angular operating range is  $\pm 25^\circ$  in both directions and the operating principle is non-contacting rotating magnetic field over hall-sensor. It is short circuit-proof (short circuit duration: unlimited).

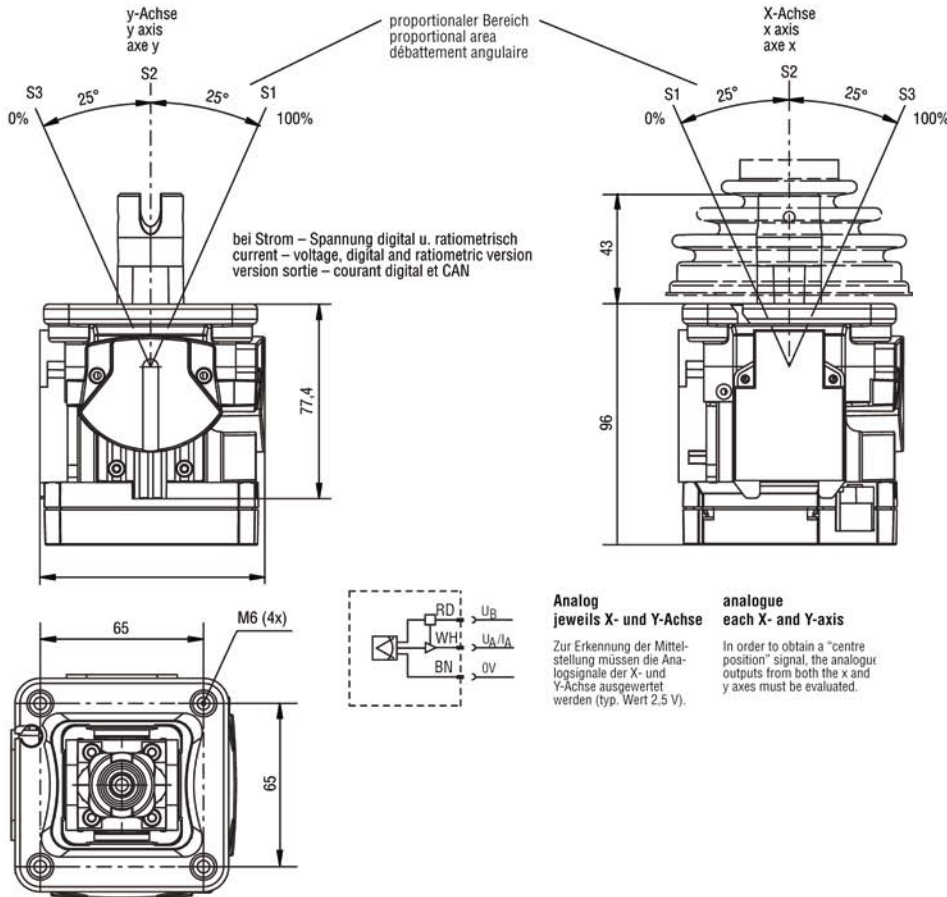

Type No.	Operating Voltage	Output Signal	Current Consumption	Load Resistance	Centre Position
EPC 700 A1	10–30 V DC	4–20 mA	max. 10 mA	1)	12 mA
EPC 100 A6	4,5–5,5 V DC	0,5–4,5 V DC ratiom./propor	MAX 10 mA	> 20 kΩ	typ. 2,5 V
EPC 100 A7	10–30 V DC	0,5–4,5 V DC	12 V -> 15 mA	> 20 kΩ	typ. 2,5 V

1) with operating voltage : 10 V < 250 Ω  
30 V < 1250 Ω

The EPC 350 is a three axis analogue control joystick. Angular operating range is  $\pm 20^\circ$  in X- and Y-directions and  $\pm 30^\circ$  in the Z-axis. The operating principle is non-contacting rotating magnetic field over hall-sensor.

### DIMENSIONS

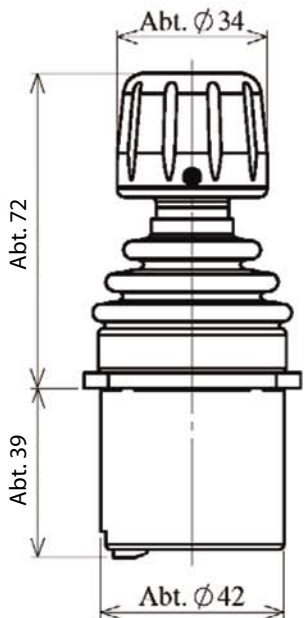
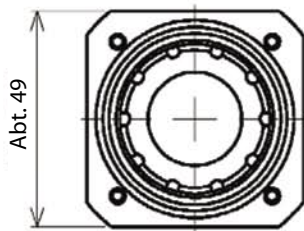

Mating connector attached (Leadwires are equivalent to AWG24)

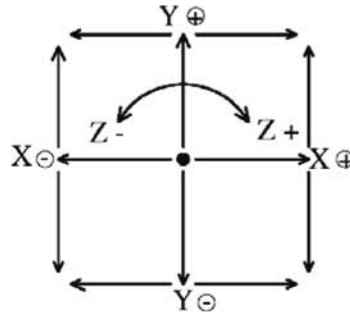

4 positions of fixing screw pan small screw, ⊕ M3×12

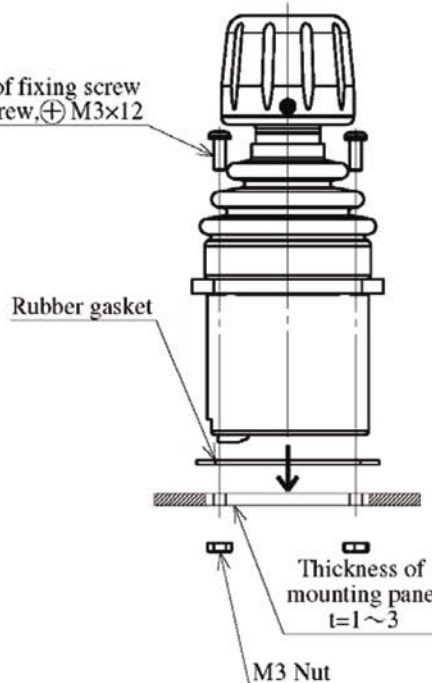

### CONNECTOR WIRING DIAGRAM

- V(+5V:10.Brown)
- OUT1(Xa:9.Red)
- OUT2(Xb:8.Orange)
- OUT3(Ya:7.Yellow)
- OUT4(Yb:6.Green)
- OUT5(Za:5.Blue)
- OUT6(Zb:4.Purple)
- G(GND:3.Gray)
- NC(2.White)
- NC(1.Black)

Notes 1. ( ) Inside expresses connector No. and color of the lead.

### OUTPUT CHARACTERISTICS

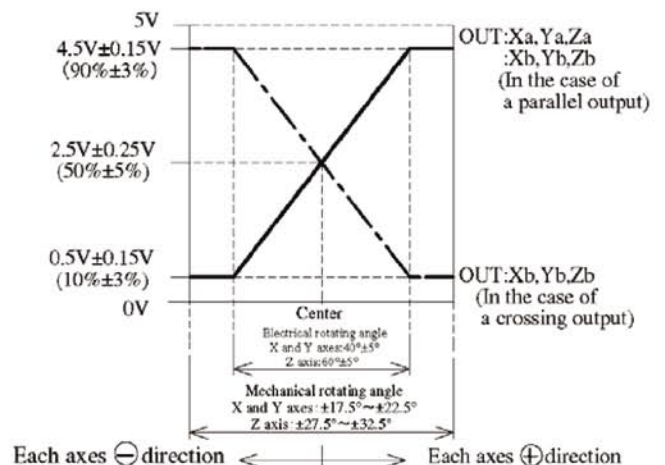



MECHANICAL PERFORMANCES	
Mechanical Operating Angle	X and Y axes : +/- 20° Z axis : +/- 30°
Operating Force	X and Y axes : 1-4N Z axis : 40-80 mNm
ELECTRICAL PERFORMANCES	
Current Consumption	Single Output : Max 33 mA Double Output : Max 66 mA
Independant Linearity Tolerance	+/- 3% FS
Electrical Rotating Angle	X and Y axes : +/- 20° (40°) Z axis : +/- 30° (60°)
Centre Return Accuracy	50% +/- 5%Vin
Applied Voltage	D.C.5V +/- 10%
Load Resistance	Over 10kΩ
Dielectric Strenght 1 minute	at 500V A.C.
Insulation Resistance	Over 1,000MΩ at 500V D.C.
Output Temperature Characteristics	Below +/- 2,5% Vout - FS
Drift at Center Position	Below +/- 1% Vout - FS
OTHERS	
Operating Temperature Range	-20°-+60° (However, not frozen)
Vibration	10-55Hz, 98m/s <sup>2</sup> (It applies to MIL-STD-202F-204)
Shock	294m/s <sup>2</sup> (It applies to MIL-STD-202F-213)
Life Expectancy	X and Y axes : Approx. 5,000,000 operations Z axis : Approx. 2,000,000 operations (The life when carrying out per minute 60 round trip operation of the knob within a mechanical operation angle is expressed with normal temperature)
Lever Strength for X and Y axes	Max. 300N (This value shows the value of static load to the part of knob)
Stopper Strenght for Z axis	Max.0.5N□m (This value shows the value of static load to the part of knob)
Index of Protection	IP=65 (This value shows the value from above panel towards knob only)
EMS Tolerance	100V/m (80MHz~1GHz with 1KHz 80% Amplitude Modulation)
ESD Tolerance	+/- 8kV contact discharge /±15kV air discharge

The EDB 64 8-64 is a PWM I/O module which is hermetically sealed in a solid aluminium capsule to protect it against the hazards of mobile environments, such as humidity and vibration.

The module is programmable through the Windows based Nimco EasyProg software.

It can be used to control up to 8 (4+4) proportional solenoids and has a CAN-bus interface. All PWM outputs have a current feedback to compensate for varying coil resistance due to heating of the solenoid valves. It can be programmed for 12 or 24 VDC operation.



Specification	
Power Supply	10-30 VDC
Voltage Ripple	<3 V t-t
CAN Protocol	2.0B 150 Kbit
CAN Driver	82C251 Philips
Number of I/O	4+4 PWM
CPU	98AZ60 Motorola
Flash Memory	60 kB
Operating Temp.	-30 - +50 Celcius
Preselections	3 (3x4)
Module IP-class	IP67
PWM Outputs	
Maximum Load	2700* mA
Current Feedback	100-1800 mA
Ramptime	0.0 - 9.9 s
Overtemp Protected	+150 Celcius
Response Time	50 ms
Shopper frequency	30 - 200 HZ
Resolution	8 bit
Error Detection	1-254 bit

### INSTALLATION DRAWING

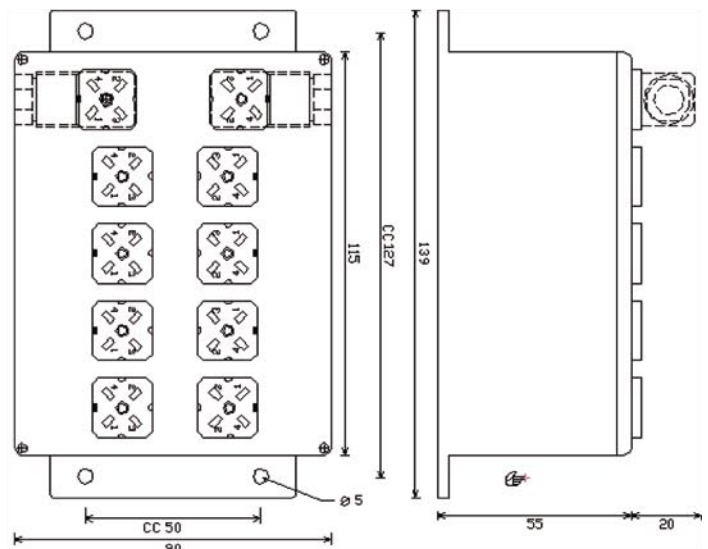
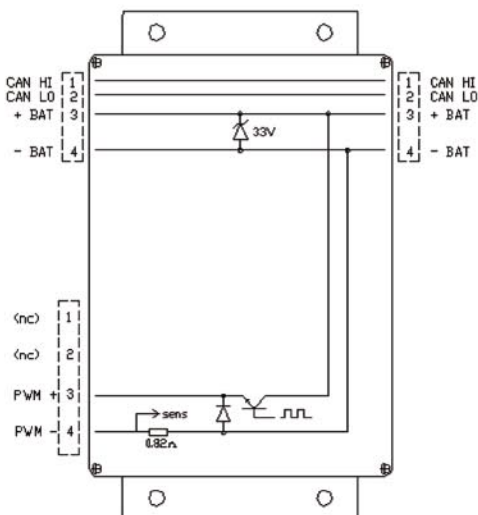

The EDB 16-64 is an I/O module with 16 (8+8) PWM outputs, 8 analogue inputs (0-5 VDC) and one digital output. It has a CAN-bus interface enabling it to be programmed and connected to other units.

The module is programmable through the Windows based Nimco EasyProg software.

It is hermetically sealed in a plastic capsule to protect it against the hazards of mobile environments, such as humidity and vibration.



Specification	
Power Supply	10-30 VDC
Voltage Ripple	<3 V t-t
CAN Protocol	2.0B 150 Kbit
CAN Driver	82C251 Philips
Analogue inputs	8 (0-5 VDC)
Digital outputs	1 (4A)
Number of PWM I/O	8+8 PWM
CPU	98AZ60 Motorola
Flash Memory	60 kB
Operating Temp.	-30 - +50 Celcius
Preselections	3 (3x4)
Module IP-class	IP67
PWM Outputs	
Maximum Load	2700* mA
Current Feedback	100-1800 mA
Ramptime	0.0 - 9.9 s
Overtemp Protected	+150 Celcius
Response Time	50 ms
Shopper frequency	30 - 200 HZ
Resolution	8 bit
Error detection	1-254 bit

### INSTALLATION DRAWING

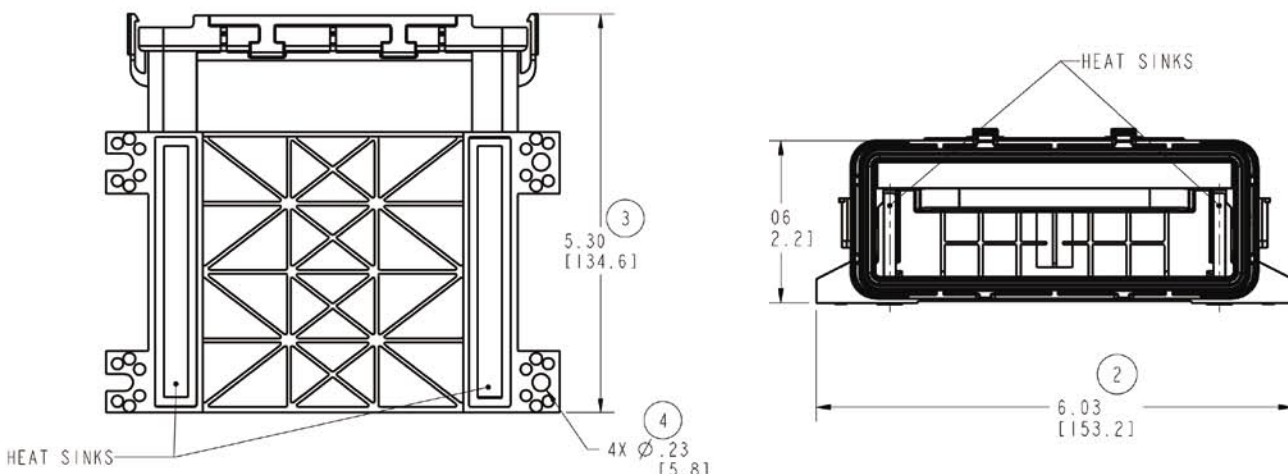

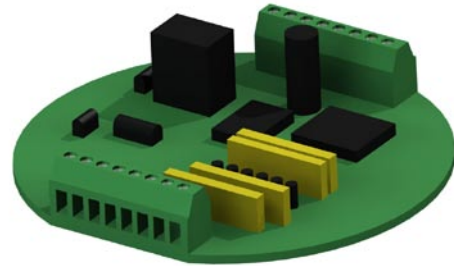

The CC8 Control card is an analogue joystick circuit board that is designed to fit underneath a joystick controller and the small size makes it ideal to fit under most joysticks. The CAN bus connection enables it to be programmed and connected to other CAN modules.

It has 8 analogue balanced inputs (0-5 VDC) for use together with a 2-axis joystick.

It comes in two different versions, either just the circuit board for integration together with a joystick (order code : CC8), or in a hermetically sealed capsule (order code : cc8-BI) as a stand alone unit.

Specification		
Power Supply	10-30	VDC
Voltage Ripple	<3	V t-t
CAN Protocol	2.0B	150Kbit
CAN Driver	82C251	Philips
Number of I/O	8	I/O
I/O Address	1-25	ID
Module Connectors	G4A5M	Hirschmann
Cable Connectors	G4W1F	Hirschmann
Operating System	CanPro	
CPU	98AZ60	Motorola
Flash Memory	60	kB
Internal Consumption	60	mA
Mass	0.04	kg
Operating Temp.	-30 - +50	Celcius

INSTALLATION DRAWING

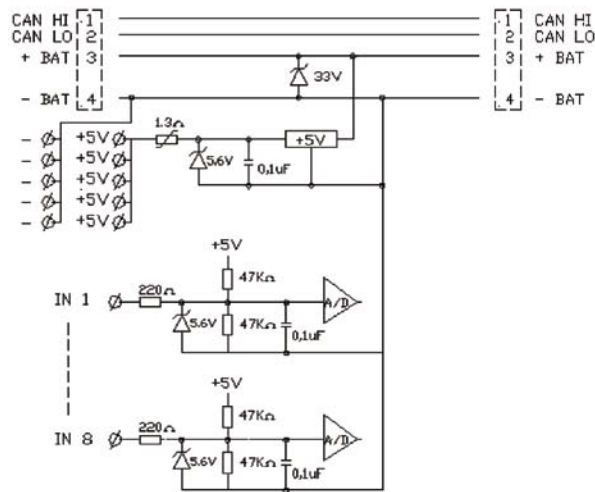
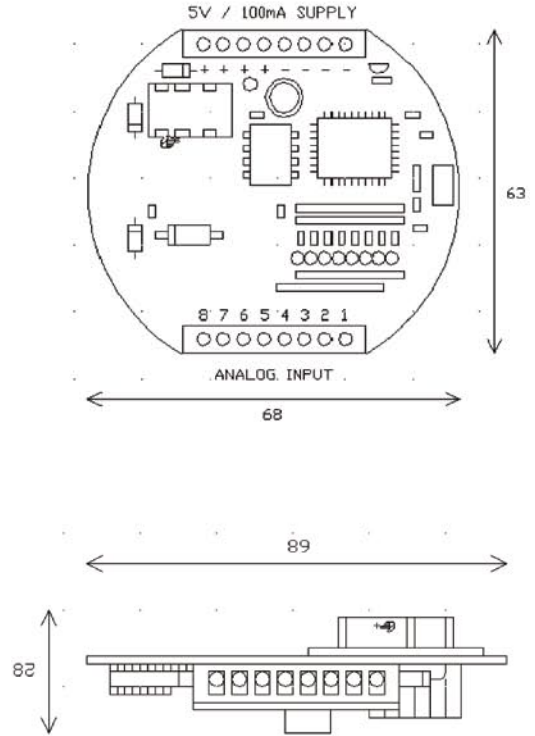
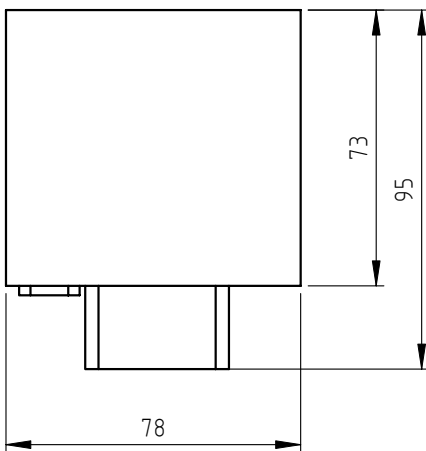
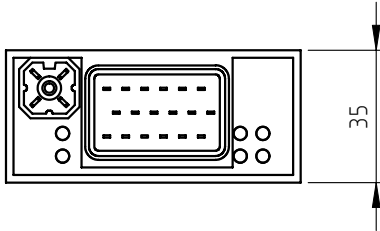

Nimco EasyProg is an easy-to-use, intuitive software for programming the different Nimco CANbus modules. The interface is based on logic programming using boolean operators to define the program instructions. A relay schematic is available as support for the programmer to get an easy-to-read overview of the program. Basically no programming experience is needed to start building programs in EasyProg.

The programs are built in three simple steps, starting by adding and configuring the different modules to be programmed, then building the program logic by setting the output conditions of each individual module port. It is easy to create subroutines that can be reused throughout the program. When the programming is finished, the program is simply downloaded to the different modules and the system is ready for use.

It is possible to upload the program from any module to make modifications, and also to make real-time analysis of the system status in form of numerical read-outs, bar graphs or histograms. This is highly useful i.e. for trouble shooting purposes or testing new software functionality.

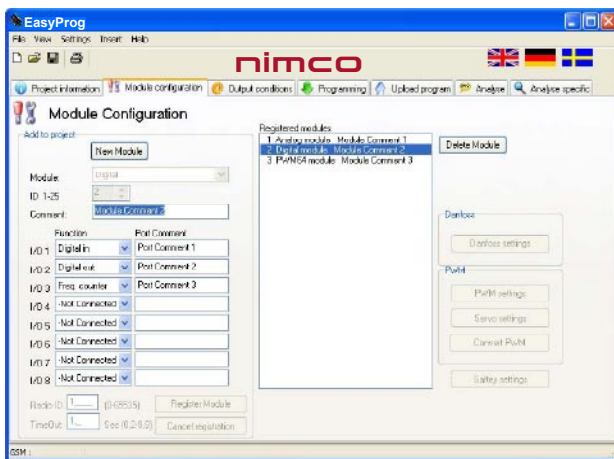

Programming window

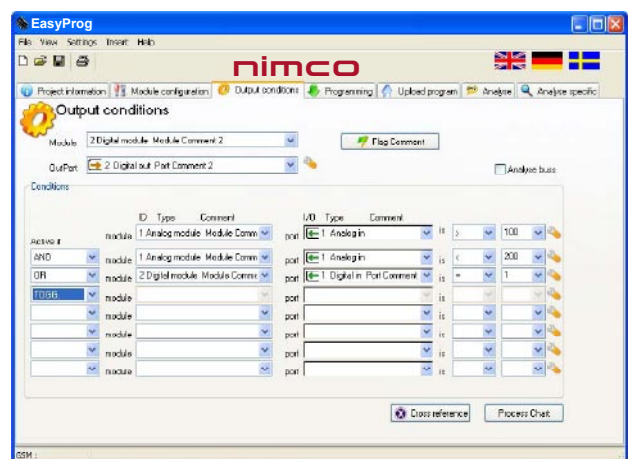

Module Configuration Window

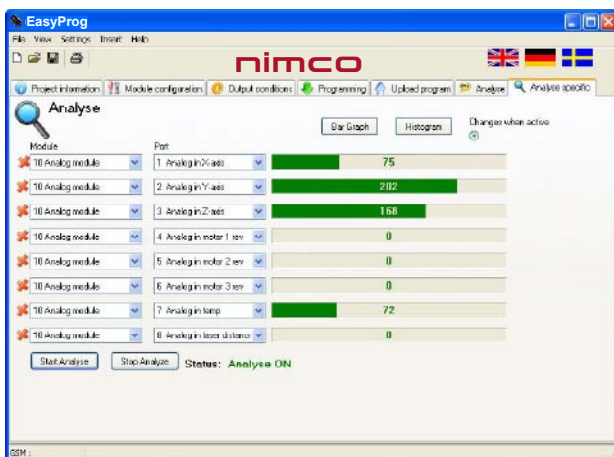

Analyse window – Bar Graphs

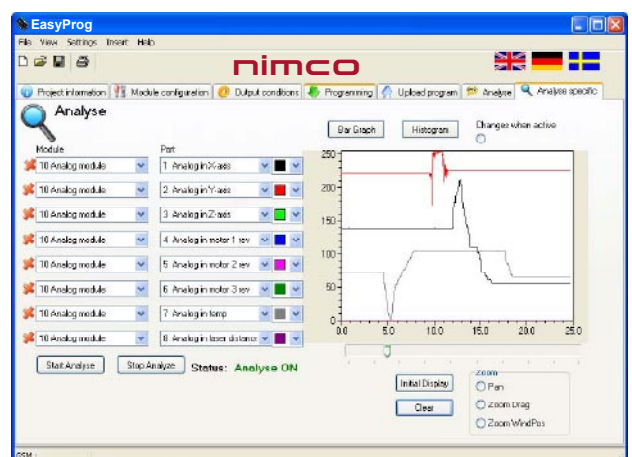

Analyse window – Histogram



WWW.NIMCO-CONTROLS.COM

# nimco

hydraulic systems

## Nimco Controls

North America & Asia  
Corporate Headquarters  
1500 S. Sylvania Avenue (USA)  
Sturtevant, WI 53177  
Phone: 262-884-0950  
salesusa@nimcous.com

## Nimco Controls

Europe  
71-75 Shelton Street  
Covent Garden, London  
WC2H 9JQ United Kingdom  
Phone: +44 20 3772 4540  
saleseurope@nimco.se

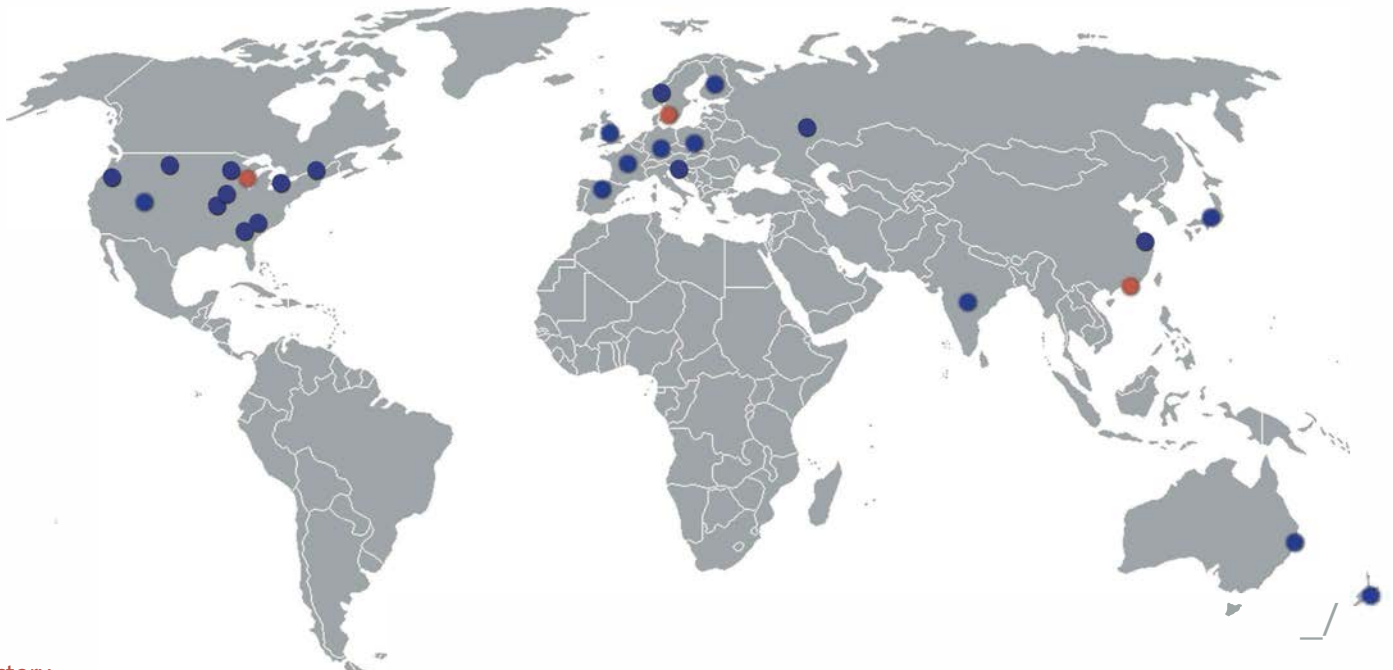

- Factory
- Distributor